

AGRICULTURAL MACHINERY

sitrex®
Spa

SPARE PARTS LIST

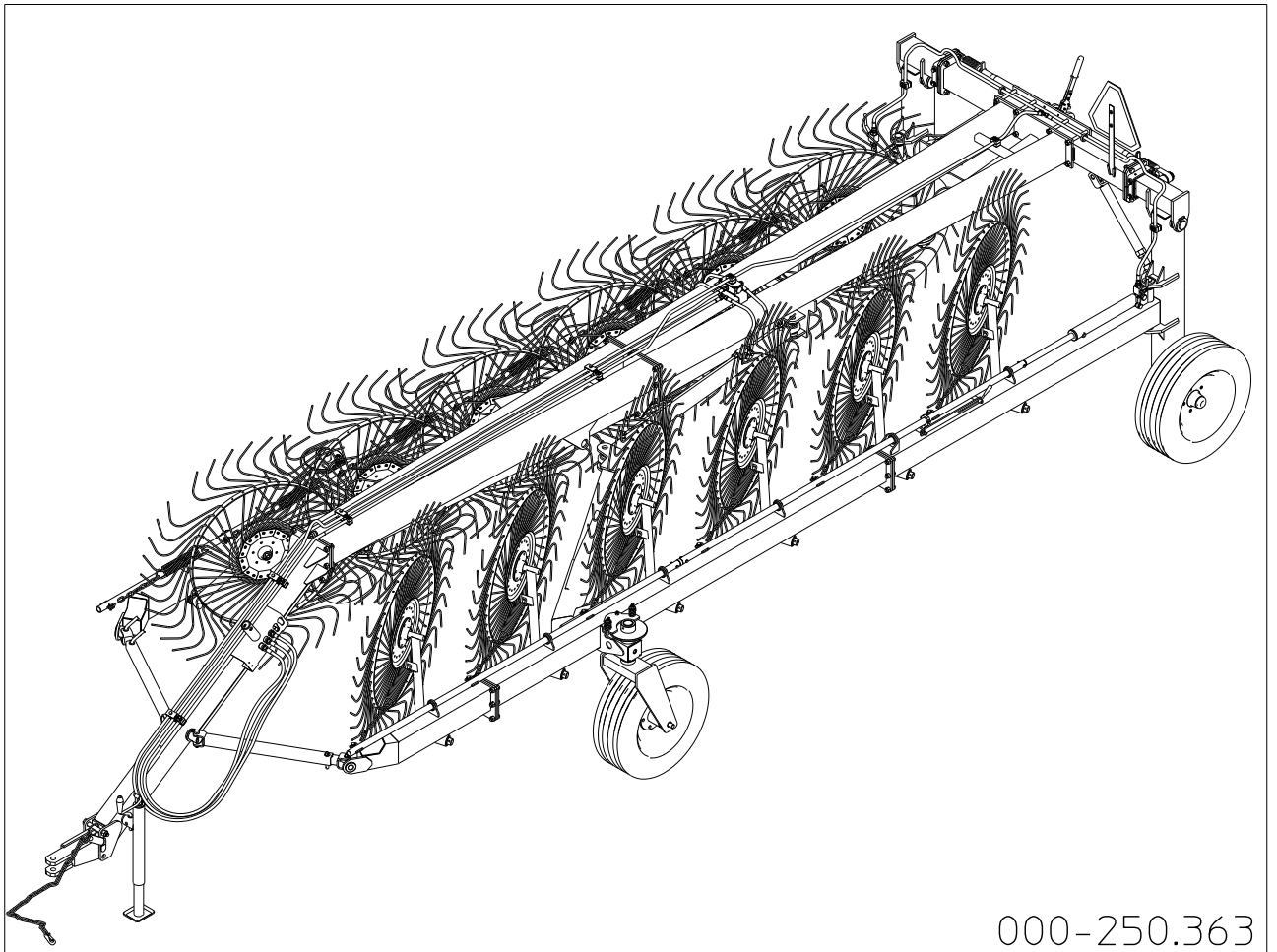

MKE/10-12

09-2016

SEE TABLE
PART NO
920.365

SEE TABLE
PART NO
920.365

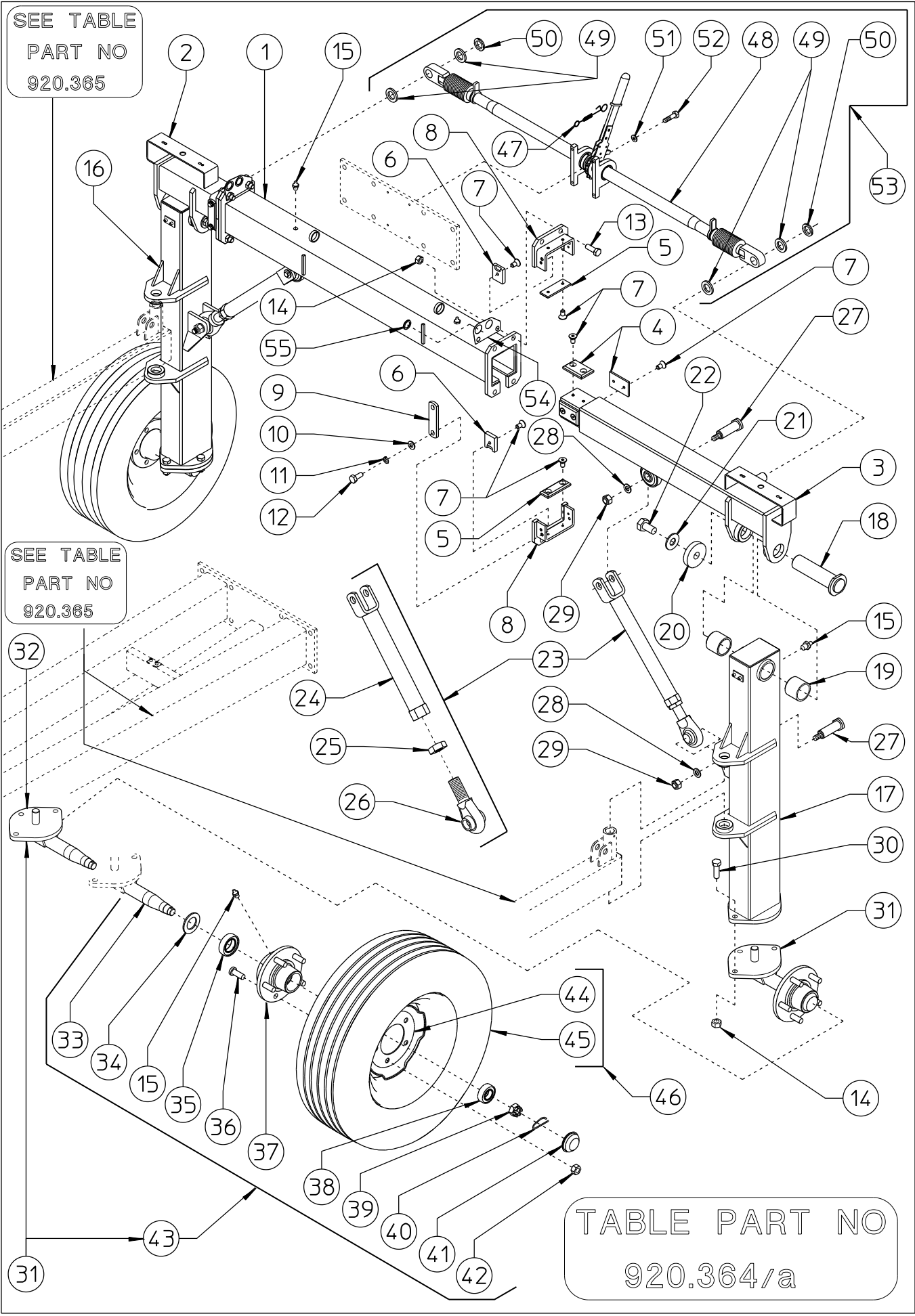

TABLE PART NO
920.364/a

TABLE PART NO 920.364/a - REAR PART (10-12 WHEELS)					
ITEM	Q.ty MKE/10	Q.ty MKE/12	SITREX PART NO	DESCRIPTION	NOTE
1	1	1	220.177	OUTER CROSSPIECE	
2	1	1	250.211	RH CROSSPIECE	
3	1	1	250.212	LH CROSSPIECE	
4	8	8	210.858	SLIDING	
5	4	4	210.911	SLIDING	
6	8	8	210.912	SLIDING	
7	32	32	610.663	SCREW M8 x 16 DIN 7991 8.8	
8	4	4	220.042	SLIDING SUPPORT	
9	4	4	220.043	LINKING PLATE	
10	8	8	600.322	WASHER D 10,5 DIN 433	
11	8	8	600.024	SPRING WASHER D 10.5 DIN 127B	
12	8	8	600.006	SCREW M10 X 25 DIN 933 8.8	
13	8	8	610.167	SCREW M16 X 45 DIN 933 8.8	
14	14	14	600.080	NUT M16 DIN 980	
15	6	6	600.034	GREASE NIPPLE M8	
16	1	1	250.284	REAR WHEEL SUPPORT,RH	
17	1	1	250.285	REAR WHEEL SUPPORT,LH	
18	2	2	210.100	PIN ϕ 50	
19	4	4	200.199	NYLON BUSH ϕ 50-60	
20	2	2	200.822	WASHER ϕ 23-75 x 12	
21	2	2	600.214	SPRING WASHER ϕ 23 DIN 127 B	
22	2	2	600.150	SCREW M22 X 50 DIN 933 8.8	
23	2	2	250.215	TIE ROD, COMPLETE	
24	2	2	250.216	TIE ROD PIPE	
25	2	2	610.813	NUT M30 DIN 936	
26	2	2	250.217	TIE ROD HEAD	
27	4	4	250.218	PIN ϕ 25	
28	4	4	600.845	WASHER ϕ 12-36x4	
29	4	4	600.077	NUT M12 DIN 980	
30	6	6	600.384	SCREW M16 X 50 DIN 933 8.8	

SEE TABLE
PART NO
920.365

SEE TABLE
PART NO
920.365

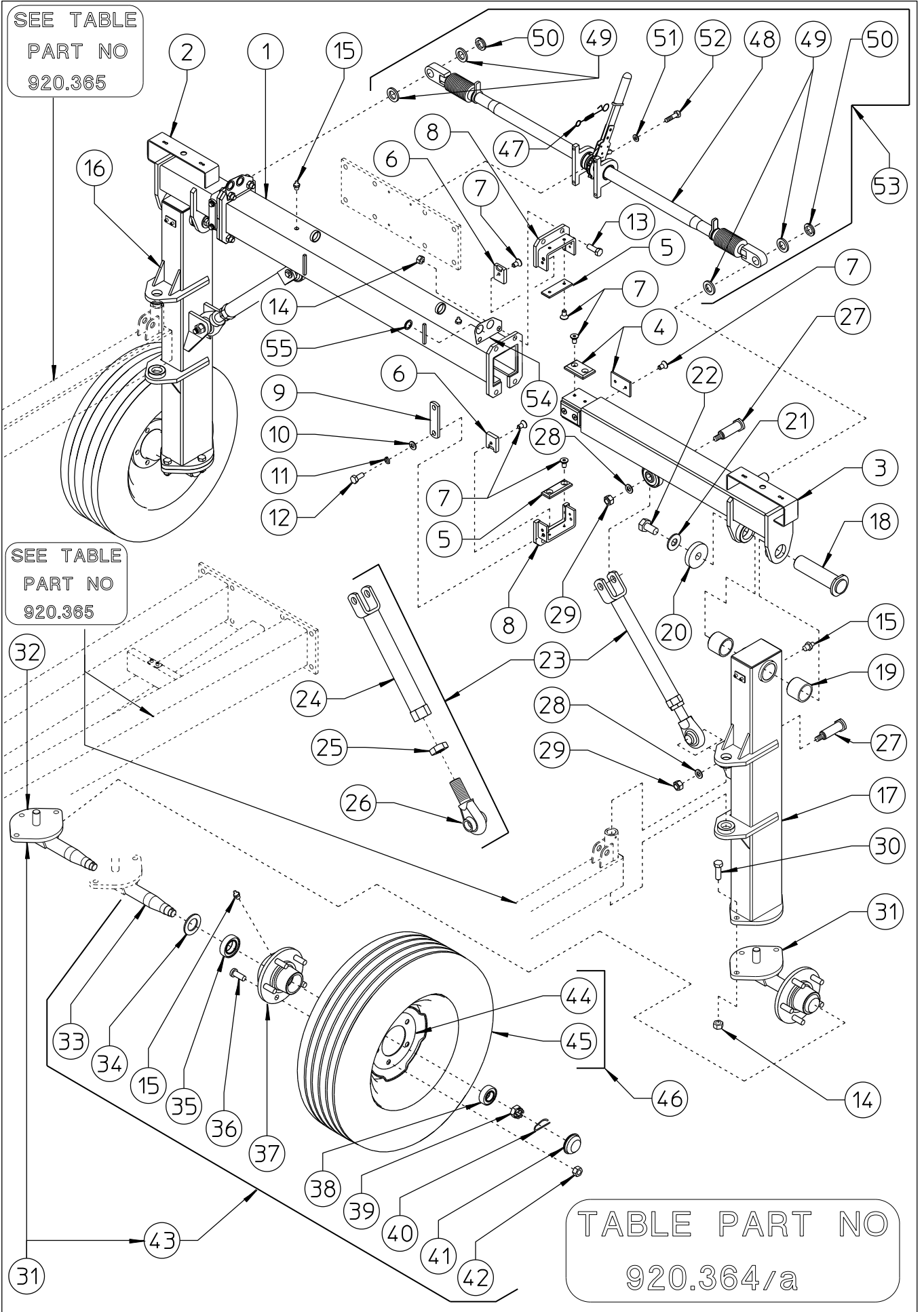

TABLE PART NO
920.364/a

TABLE PART NO 920.364/a - REAR PART (10-12 WHEELS)

ITEM	Q.ty MKE/10	Q.ty MKE/12	SITREX PART NO	DESCRIPTION	NOTE
31	2	2	250.219	HUB ASSY	
32	2	2	250.220	FLANGE WITH PIN	
33	2	2	215.781	PIN ONLY	
34	2	2	600.284	DUST COVER	
35	2	2	600.285	BEARING 30208	
36	10	10	610.413	SCREW M16x1,5x50	
37	2	2	600.286	HUB WITH SCREWS	
38	2	2	600.287	BEARING 30206	
39	2	2	600.288	SLOTTED NUT M27 X 1,5	
40	2	2	600.291	SPLIT PIN ϕ 3	
41	2	2	600.290	CAP	
42	10	10	600.289	NUT M16x1,5	
43	2	2	215.782	HUB WITHOUT FLANGE	
44	2	2	600.304	RIM 6Jx15	
45	2	2	600.303	TIRE 205/75-15	
46	2	2	600.281	WHEEL ASSY	
47	1	1	220.378	LOCK SPRING	
48	1	1	210.981	RATCHET LINK	
49	4	4	220.208	SHIM ϕ 30,5-50x6	
50	2	2	610.593	LOCK-NUT M30 X 1,5	
51	4	4	600.229	SPRING WASHER ϕ 8,5 DIN 127B	
52	4	4	600.757	SCREW M8 X 30 DIN 933 8.8	
53	1	1	220.260	RATCHET LINK, COMPLETE KIT	
54	2	2	250.409	HOSE SUPPORT	
55	4	4	631.711	GASKET	

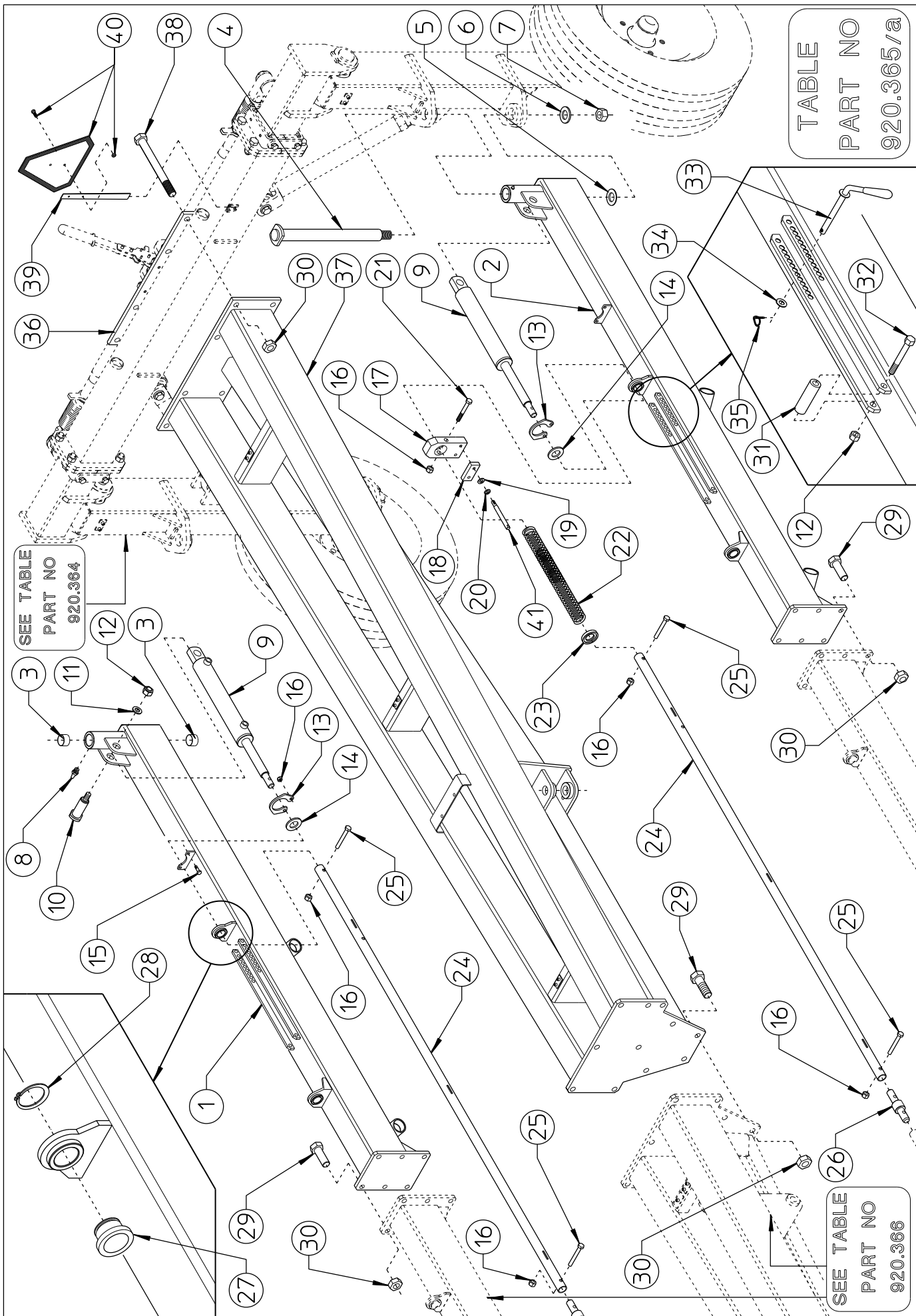

TABLE PART NO 920.365/a - REAR SECTIONS AND DRAWBAR (10-12 WHEELS)					
ITEM	Q.ty MKE/10	Q.ty MKE/12	SITREX PART NO	DESCRIPTION	NOTE
1	1	1	250.288	RH SECTION	
2	1	1	250.289	LH SECTION	
3	4	4	640.024	BUSH ϕ 35-39x30	
4	2	2	250.295	PIN	
5	2	2	200.475	SHIM ϕ 35,2-51,8x1,5	
6	2	2	200.165	WASHER ϕ 23-50x4	
7	2	2	600.079	NUT M22 DIN 980	
8	2	2	600.034	GREASE NIPPLE M8	
9	2	2	250.238	CILINDER ϕ 50-60 ROD ϕ 30	
10	2	2	250.240	PIN ϕ 25	
11	2	2	600.845	WASHER ϕ 12-36x4	
12	4	4	600.077	NUT M12 DIN 980	
13	2	2	220.526	CYLINDER LOCKING PLATE	
14	2	2	250.241	SHIM ϕ 25,25-35x4	
15	4	4	600.702	SCREW M8x25 DIN 931 8.8	
16	10	10	600.076	NUT M8 DIN 980	
17	2	2	250.242	SUPPORT	
18	2	2	250.243	SLIDING	
19	4	4	600.115	WASHER ϕ 8,4 DIN 125A	
20	4	4	600.229	SPRING WASHER ϕ 8,5 DIN 127B	
21	2	2	610.525	SCREW M8x60 DIN 931 8.8	
22	2	2	250.244	SPRING ϕ 6 L.600-23,6"	
23	2	2	250.245	BUSH ϕ 34,5-50-60 x 20	
24	2	2	250.247	PIPE ϕ 33,7x4 L.2515-99"	
25	4	4	600.551	SCREW M8x45 DIN 931 8.8	
26	2	2	250.266	PIN ϕ 25-35	
27	4	4	250.250	NYLON BUSH ϕ 34,5	
28	4	4	630.957	SNAP RING E42 DIN 471	
29	22	22	610.167	SCREW M16x45 DIN 933 8.8	
30	30	30	600.080	NUT M16 DIN 980	
31	2	2	250.251	BUSH ϕ 12,5-20	
32	2	2	600.007	SCREW M12x85 DIN 931 8.8	
33	2	2	250.252	HANDLE	
34	2	2	600.089	WASHER ϕ 13 DIN 125A	
35	2	2	600.723	SPLIT PIN ϕ 4,5	
36	1	1	220.176	DRAWBAR COUNTERPLATE	
37	1	1	250.296	REAR DRAWBAR	
38	8	8	610.839	SCREW M16x165 DIN 931 8.8	
39	1	1	220.413	SUPPORT	
40	1	1	220.414	SMV EMBLEME ASAES276.7	
41	4	4	250.365	PIN ϕ 12	

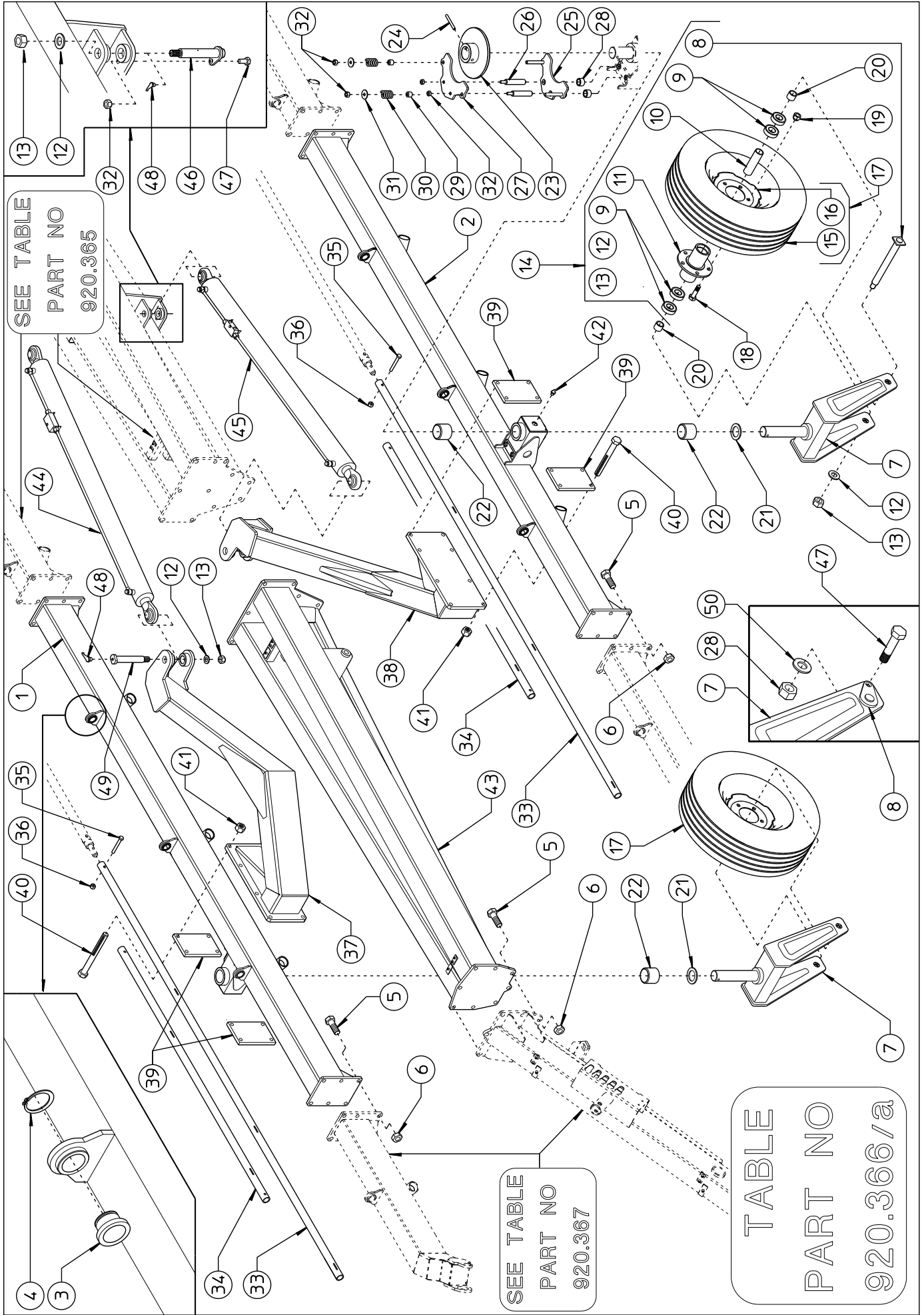

TABLE PART NO 920.366/a - CENTER SECTIONS AND DRAWBAR (10-12 WHEELS)					
ITEM	Q.ty MKE/10	Q.ty MKE/12	SITREX PART NO	DESCRIPTION	NOTE
1	1	1	260.107	RH SECTION (3 WHEELS)	
2	1	1	260.108	LH SECTION (3 WHEELS)	
3	6	6	250.250	NYLON BUSH ϕ 34,5	
4	6	6	630.957	SNAP RING E42 DIN 471	
5	20	20	610.167	SCREW M16x45 DIN 933 8.8	
6	20	20	600.080	NUT M16 DIN 980	
7	2	2	250.253	WHEEL SUPPORT	
8	2	2	250.254	PIN ϕ 30	
9	8	8	600.609	BEARING 6206 2RS	
10	2	2	250.210	SPACER	
11	2	2	250.209	HUB	
12	6	6	200.165	WASHER ϕ 23-50x4	
13	6	6	600.079	NUT M22 DIN 980	
14	2	2	250.255	HUB ASSY	
15	2	2	600.303	TIRE 205-75	
16	2	2	600.304	WHEEL RIM 6Jx15	
17	2	2	600.281	COMPLETE WHEEL 205/75-R15	
18	10	10	600.144	SCREW M16x1,5 x 40 DIN 961	
19	10	10	600.289	NUT M16x1,5	
20	4	4	210.170	SPACER	
21	2	2	210.179	SHIM ϕ 50-75x5	
22	4	4	200.199	NYLON BUSH ϕ 50-60x50	
23	2	2	200.025	BRAKE FLANGE	
24	2	2	600.033	SPRING PIN ϕ 10x80 DIN 1481	
25	2	2	260.083	BRAKE COUNTERPLATE	
26	4	4	260.092	PIN ϕ 20-M12	
27	2	2	260.082	BRAKE PLATE	
28	4	4	260.091	SHIM ϕ 21-30x10	
29	4	4	250.259	SPACER	
30	4	4	200.044	SPRING ϕ 5- ϕ 30x45	

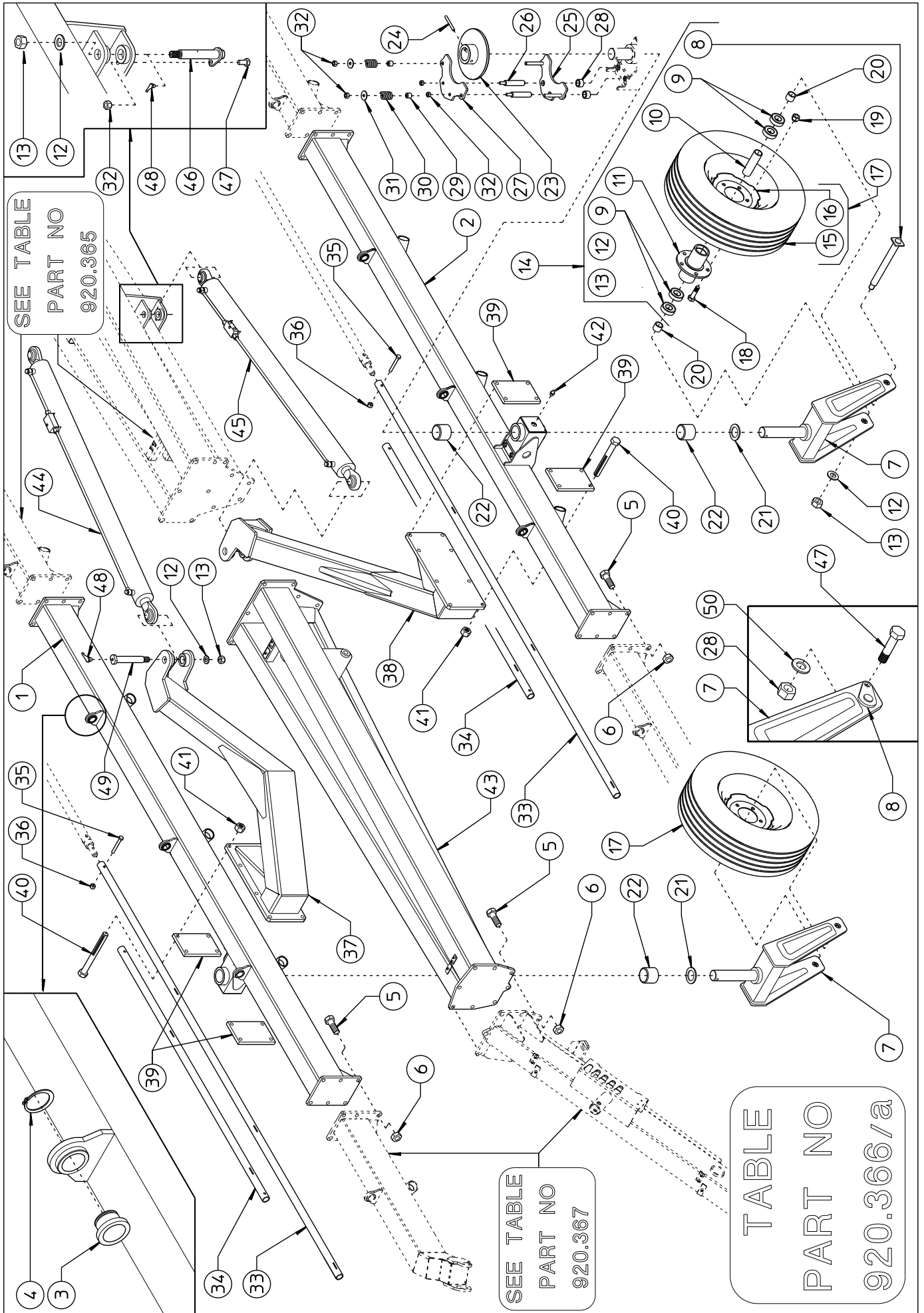

TABLE PART NO 920.366/a - CENTER SECTIONS AND DRAWBAR (10-12 WHEELS)					
ITEM	Q.ty	Q.ty	SITREX	DESCRIPTION	NOTE
	MKE/10	MKE/12	PART NO		
31	4	4	600.845	WASHER ϕ 12-36x4	
32	12	12	600.077	NUT M12 DIN 980	
33	*	2	250.248	PIPE ϕ 33,7 L.2415-95,08" (MK12 only)	
34	2	*	250.246	PIPE ϕ 33,7 L.1670-65,75" (MK10 only)	
35	2	2	600.551	SCREW M8x45 DIN 931 8.8	
36	2	2	600.076	NUT M8 DIN 980	
37	1	1	250.260	RH ARM	
38	1	1	250.261	LH ARM	
39	4	4	250.262	COUNTERPLATE	
40	16	16	610.612	SCREW M14x140 DIN 931 8.8	
41	16	16	600.075	NUT M14 DIN 980	
42	2	2	600.034	GREASE NIPPLE M8	
43	1	1	250.236	DRAWBAR	
44	1	1	250.298	RH CYLINDER WITH VALVE	
45	1	1	250.299	LH CYLINDER WITH VALVE	
46	2	2	250.264	PIN ϕ 30	
47	4	4	600.616	SCREW M12x35 DIN 933 8.8	
48	4	4	600.968	GREASE NIPPLE M6x45°	
49	2	2	250.265	PIN ϕ 30	
50	2	2	600.089	WASHER ϕ 13 DIN 125A	

SEE TABLE
PART NO
920.366

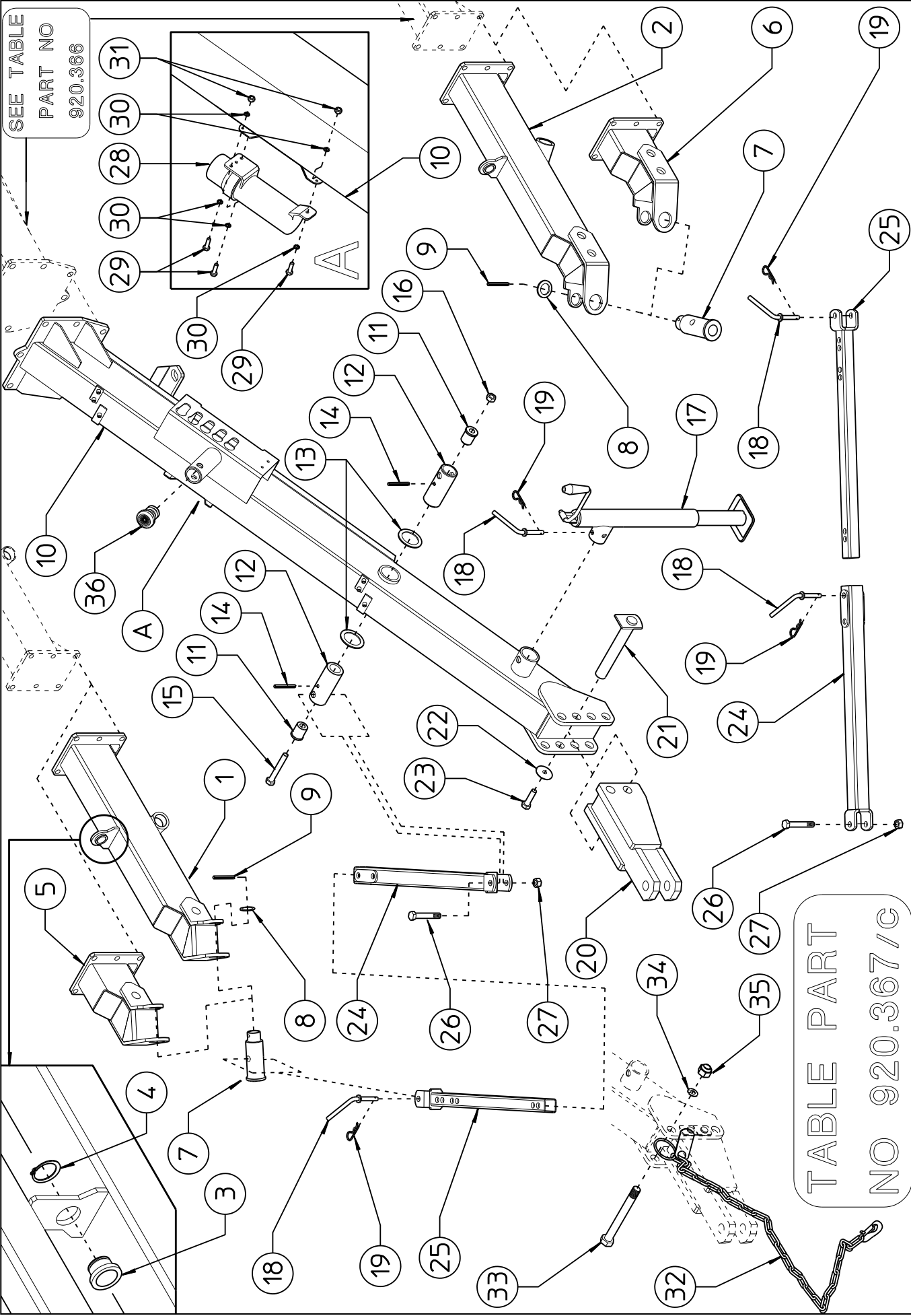

TABLE PART
NO 920.367/C

TABLE PART NO 920.367/c - FRONT SECTIONS AND DRAWBAR (10-12 WHEELS)					
ITEM	Q.ty MKE/10	Q.ty MKE/12	SITREX PART NO	DESCRIPTION	NOTE
1	*	1	250.689	RH SECTION (1 WHEEL)	
2	*	1	250.690	LH SECTION (1 WHEEL)	
3	*	2	250.250	NYLON BUSH ϕ 34,5	
4	*	2	630.957	SNAP RING E42 DIN 471	
5	1	*	250.691	RH HITCH	
6	1	*	250.692	LH HITCH	
7	2	2	250.267	BUSHING	
8	2	2	250.268	SHIM ϕ 39-50x3	
9	2	2	600.027	SPRING PIN ϕ 8x50 DIN 1481	
10	1	1	250.237	FRONT DRAWBAR	
11	2	2	250.269	BUSHING	
12	2	2	250.270	BUSHING	
13	2	2	250.126	SHIM ϕ 50,5-70x3	
14	2	2	600.447	SPRING PIN ϕ 8x70 DIN 1481 PLATED	
15	1	1	610.516	SCREW M12x100 DIN 931 8.8	
16	1	1	600.077	NUT M12 DIN 980	
17	1	1	220.166	PARKING STAND	
18	5	5	200.222	PIN ϕ 15	
19	5	5	600.019	HAIRPIN ϕ 3	
20	1	1	250.271	TRACTOR HITCH	
21	2	2	200.828	PIN ϕ 25	
22	2	2	600.845	WASHER ϕ 12-36x4	
23	2	2	600.770	SCREW M12x20 DIN 933 8.8	
24	2	2	250.272	OUTER ARM	
25	2	2	250.273	INNER ARM	
26	2	2	610.872	SCREW M16x90 DIN 931 8.8	
27	2	2	600.080	NUT M16 DIN 980	
28	1	1	230.457	CANISTER	
29	3	3	630.003	SCREW M6x20 DIN 933 8.8	
30	6	6	600.135	WASHER ϕ 6,6-18x2	
31	3	3	600.472	NUT M6 DIN 980	
32	1	1	220.500	SAFETY CHAIN	
33	1	1	620.019	SCREW M22x150 DIN 931 8.8	
34	1	1	600.214	SPRING WASHER ϕ 23 similar to DIN 127 B	
35	1	1	600.200	NUT M22 DIN 934	
36	1	1	610.790	PLUG	

TABLE
PART NO
920.368

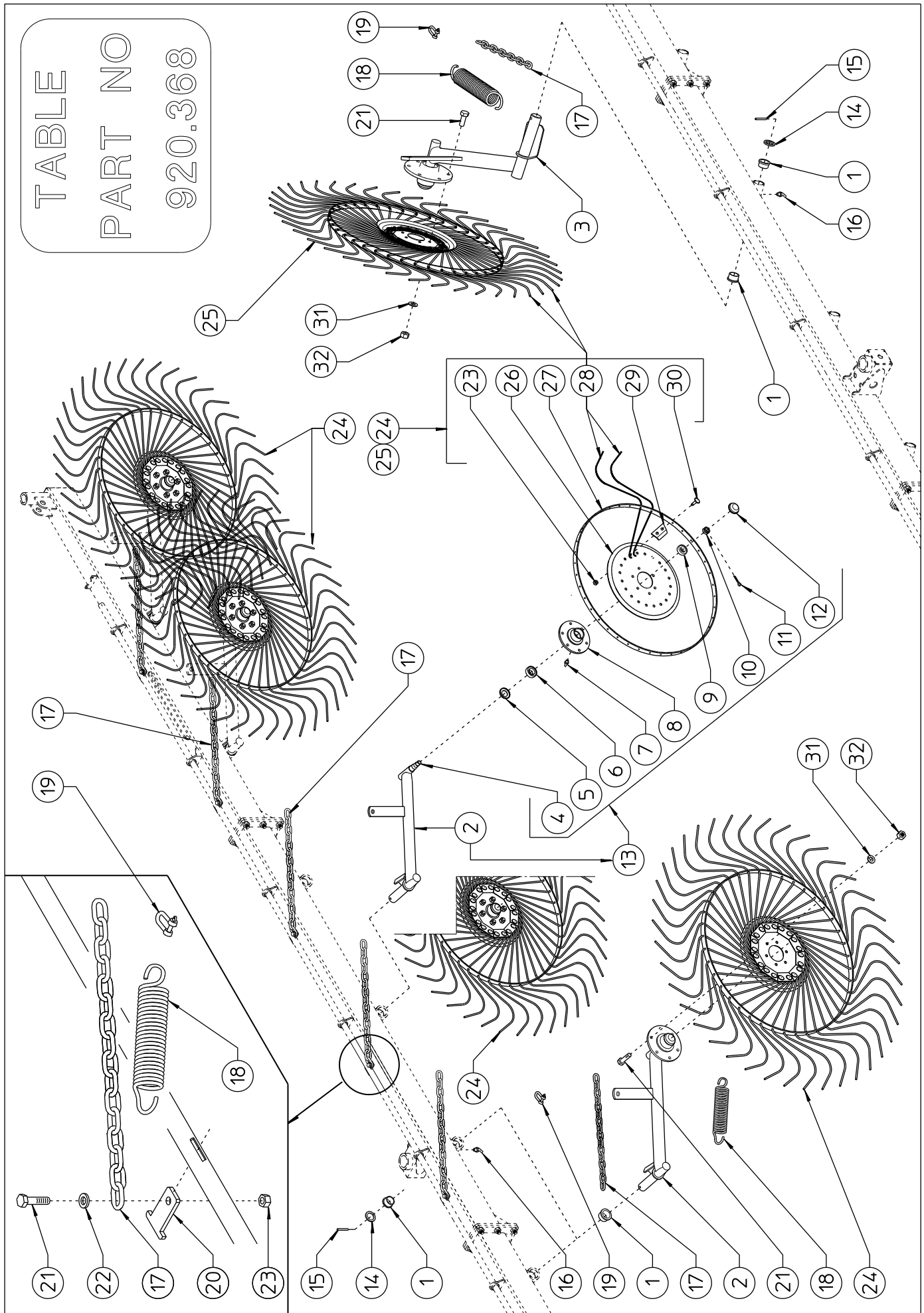
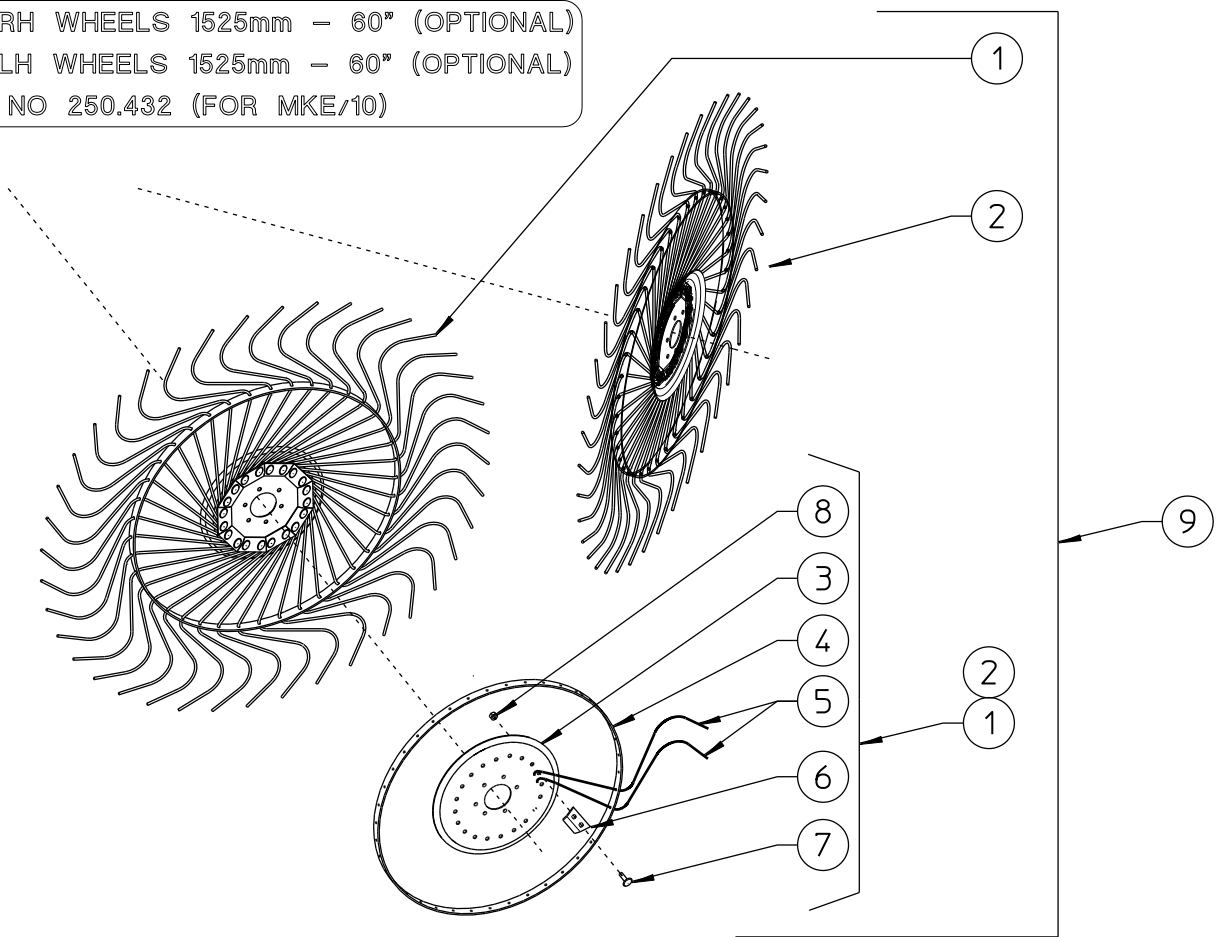

TABLE PART NO 920.368 - ARMS, WHEELS 1400-55" AND ACCESORIES (10-12 WHEELS)

ITEM	Q.ty MKE/10	Q.ty MKE/12	SITREX PART NO	DESCRIPTION	NOTE
1	20	24	200.029	BUSHING	
2	5	6	250.280	RH ARMS	
3	5	6	250.281	LH ARMS	
4	10	12	205.277	PIN	
5	10	12	600.011	DUST COVER	
6	10	12	600.012	BEARING 30205	
7	10	12	600.034	GREASE NIPPLE M8	
8	10	12	600.013	HUB	
9	10	12	600.014	BEARING 30204	
10	10	12	600.015	SLOTTED NUT M18x1,5	
11	10	12	600.301	SPLIT PIN ϕ 3x30 DIN 94	
12	10	12	600.016	CAP	
13	10	12	205.041	HUB ASSY	
14	10	12	200.028	WASHER ϕ 35-50x5	
15	10	12	600.027	SPLIT PIN ϕ 8x50 DIN 1481	
16	10	12	600.968	GREASE NIPPLE M6x45°	
17	10	12	250.282	CHAIINE	
18	10	12	200.046	SPRING	
19	10	12	610.317	"D" SACKLES	
20	10	12	250.283	SUPPORT	
21	70	84	600.006	SCREW M10x25 DIN 933 8.8	
22	10	12	620.250	WASHER ϕ 11-30x2,5 UNI 6593	
23	210	252	600.029	NUT M10 DIN 980	
24	5	6	210.180	RH FINGER WHEEL 1400mm – 55"	
25	5	6	210.181	LH FINGER WHEEL 1400mm – 55"	
26	10	12	200.010	FLANGE	
27	10	12	200.009	RIM	
28	400	480	210.621	TINE ϕ 7	
29	100	120	200.012	TINE CLAMP	
30	200	240	600.005	SCREW M10x25 DIN 603	
31	60	72	600.024	SPRING WASHER ϕ 10,5 DIN 127B	
32	60	72	600.010	NUT M10 DIN 934	

N° 5 RH WHEELS 1525mm - 60" (OPTIONAL)
 N° 5 LH WHEELS 1525mm - 60" (OPTIONAL)
 PART NO 250.432 (FOR MKE/10)



N° 6 RH WHEELS 1525mm - 60" (OPTIONAL)
 N° 6 LH WHEELS 1525mm - 60" (OPTIONAL)
 PART NO 250.433 (FOR MKE/12)

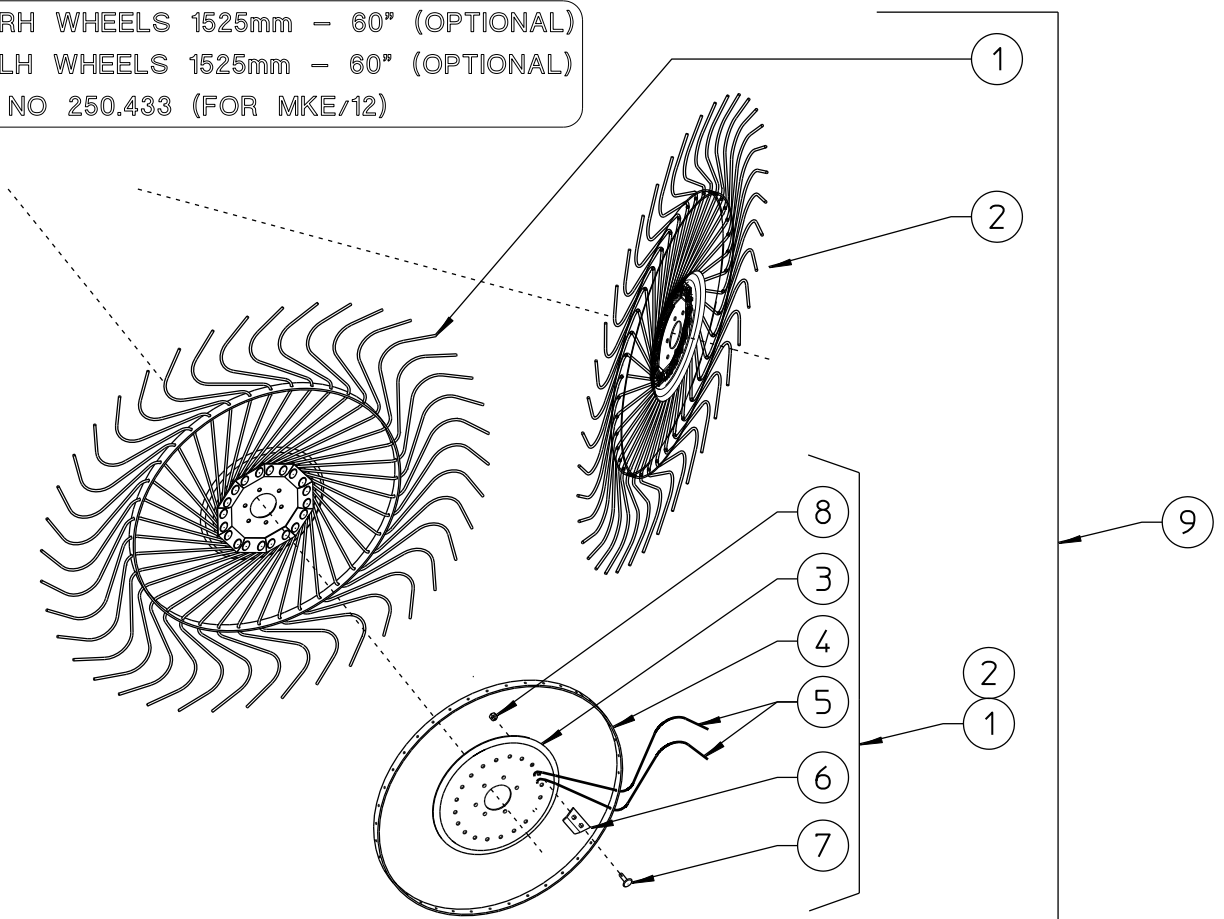

RAKE WHEELS 1525mm - 60" OPTIONAL KIT FOR MKE/10			
ITEM	Q.ty	PART NO	DESCRIPTION
1	5	230.279	RH FINGER WHEEL 60"
2	5	230.280	LH FINGER WHEEL 60"
3	10	230.338	FLANGE
4	10	230.326	RIM
5	400	230.327	TINE ϕ 7,5
6	100	200.012	TINE CLAMP
7	200	600.010	SCREW M10x25 DIN 603
8	200	600.029	NUT M10 DIN 980
9	1	250.432	RAKE WHEELS KIT 60" FOR MKE/10 OPTIONAL

RAKE WHEELS 1525mm - 60" OPTIONAL KIT FOR MKE/12			
ITEM	Q.ty	PART NO	DESCRIPTION
1	6	230.279	RH FINGER WHEEL 60"
2	6	230.280	LH FINGER WHEEL 60"
3	12	230.338	FLANGE
4	12	230.326	RIM
5	480	230.327	TINE ϕ 7,5
6	120	200.012	TINE CLAMP
7	240	600.010	SCREW M10x25 DIN 603
8	240	600.029	NUT M10 DIN 980
9	1	250.433	RAKE WHEELS KIT 60" FOR MKE/12 OPTIONAL

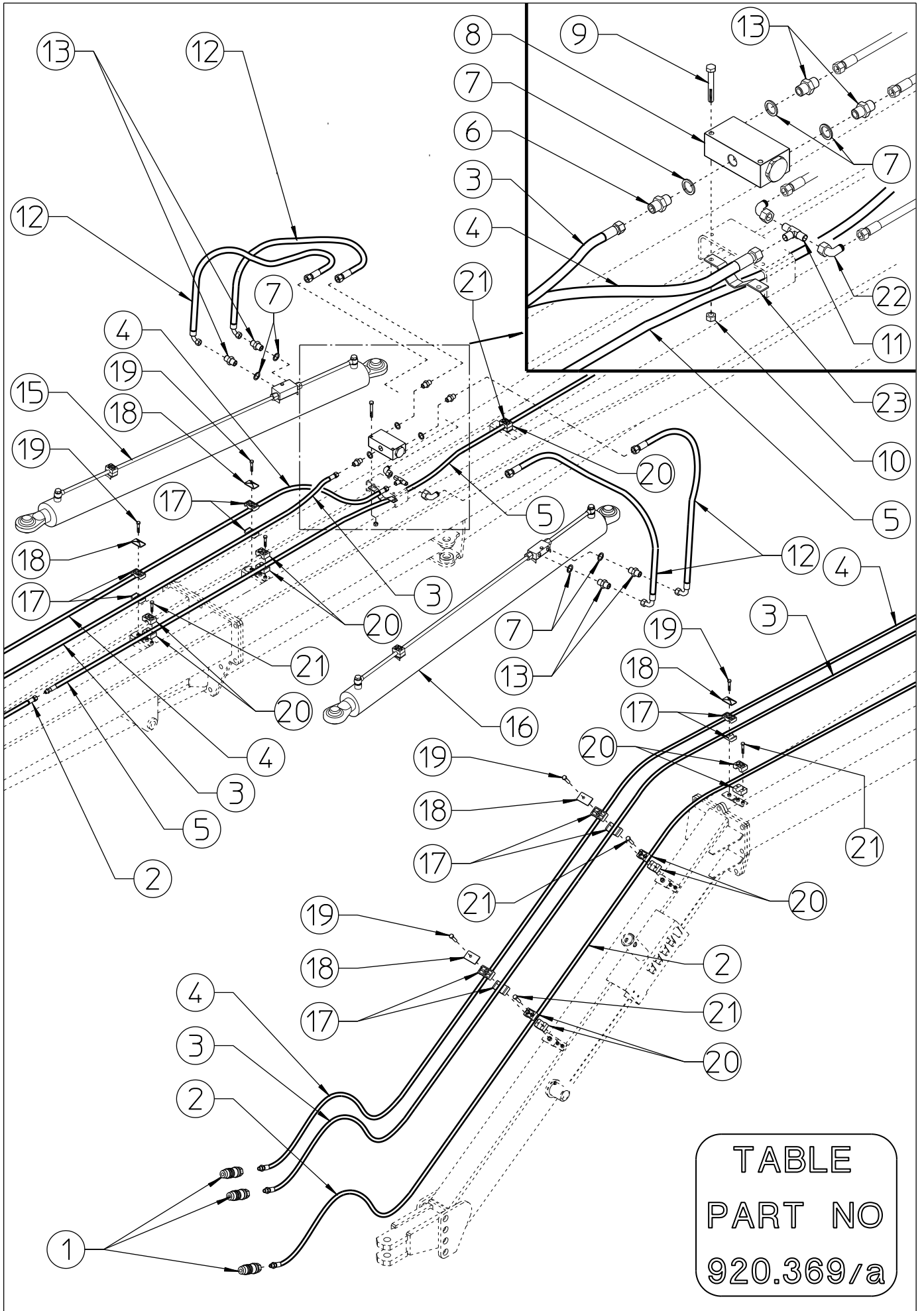

TABLE PART NO 920.369/a - FRONT HYDRAULIC COMPONENTS (FRONT) (10-12 WHEELS)

ITEM	Q.ty MKE/10	Q.ty MKE/12	SITREX PART NO	DESCRIPTION	NOTE
1	3	3	620.329	RAPID COUPLINGS 1/2" NPTM	
2	1	1	640.032	HOSE 3/8" L.4550-179,13" 1/2" NPTF- M JIC 3/4"	
3	1	1	640.030	HOSE 1/2" L.6500-255,91" 1/2" NPTF- F JIC 7/8"	
4	1	1	640.031	HOSE 1/2" L.6600-259,84" 1/2" NPTF- F JIC 3/4"	
5	1	1	640.033	HOSE 3/8" L.4300-169,29" M JIC 3/4" - F JIC 3/4"	
6	1	1	640.034	NIPPLE JIC 7/8" - 3/8" GAS	
7	7	7	620.452	WASHER ϕ 3/8" BONDED	
8	1	1	600.974	FLOW DIVIDER 3/8"	
9	2	2	600.970	SCREW M6x60 DIN 931	
10	2	2	600.472	NUT M6 DIN 980	
11	1	1	640.036	"T" FITTING - MALE JIC 3/4"	
12	4	4	640.038	HOSE 3/8" L.750-29,53" F JIC 3/4" - F90° JIC 3/4"	
13	6	6	640.035	NIPPLE 3/8" GAS - JIC 3/4"	
14	DELETED				
15	1	1	250.298	RH CYLINDER ϕ 70-45 WITH VALVE	
16	1	1	250.299	LH CYLINDER ϕ 70-45 WITH VALVE	
17	10	10	610.041	DOUBLE HOSE COLLAR ϕ 22-22	
18	5	5	610.043	LOCK	
19	5	5	610.044	SCREW M8x45 DIN 933	
20	12	12	610.035	HOSE COLLAR ϕ 18	
21	12	12	610.037	SCREW M6x25 DIN 912	
22	2	2	640.057	FITTING 90° M 3/4" JIC - F 3/4" JIC	
23	1	1	250.366	HOSE SUPPORT	

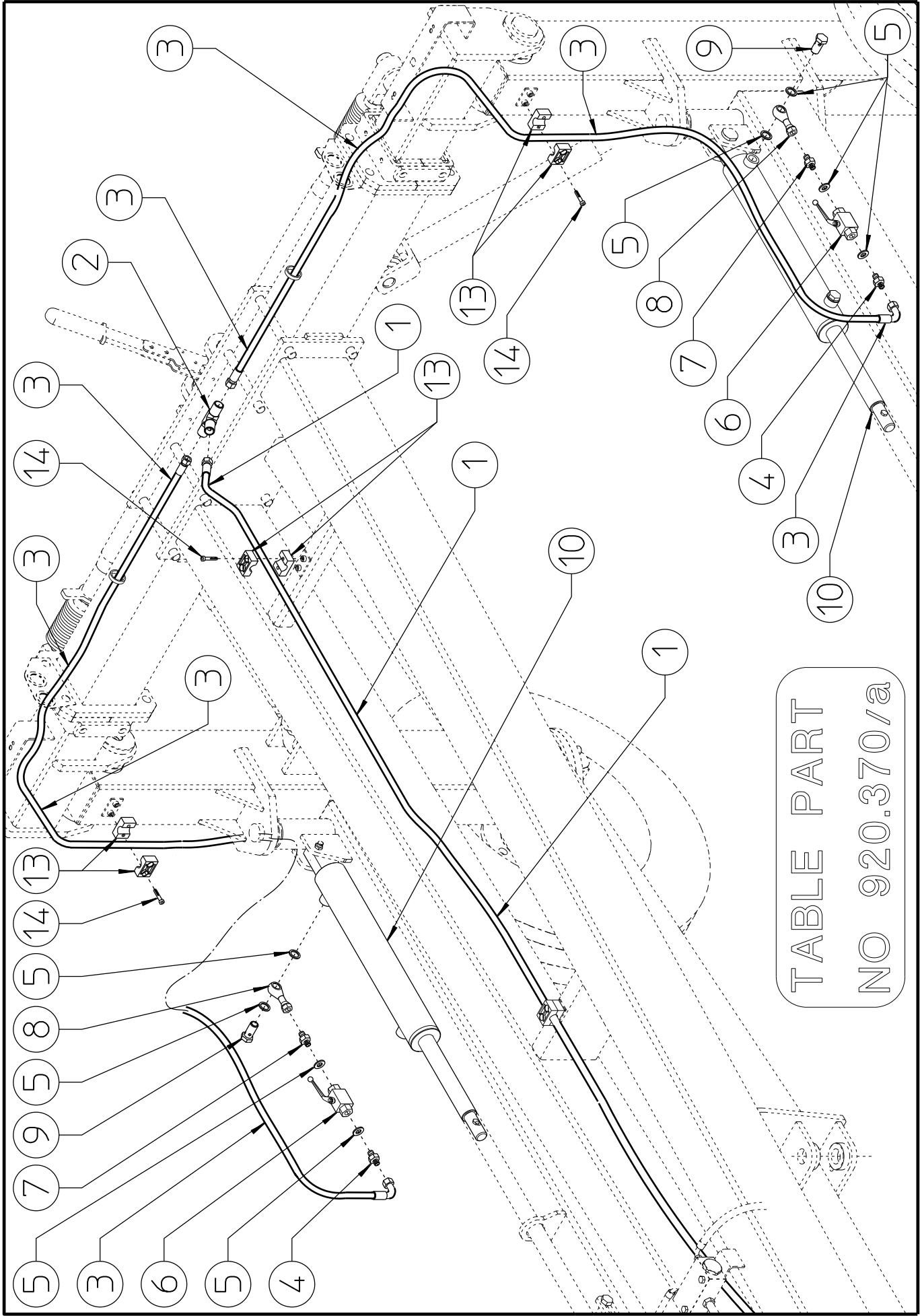

TABLE PART
NO 920.370/a

TABLE PART NO 920.370/a - FRONT HYDRAULIC COMPONENTS (REAR PART) (10-12 WHEELS)					
ITEM	Q.ty	Q.ty	SITREX	DESCRIPTION	NOTE
	MKE/10	MKE/12	PART NO		
1	1	1	640.033	HOSE 3/8" L.4300-169,29" M JIC 3/4" - F JIC 3/4"	
2	1	1	640.036	"T" FITTING - MALE JIC 3/4"	
3	2	2	640.063	HOSE 3/8" L.1840-72.44" F JIC 3/4" – F90° JIC 3/4"	
4	2	2	640.035	NIPPLE 3/8" GAS - JIC 3/4"	
5	8	8	620.452	WASHER ø3/8" BONDED	
6	2	2	610.002	VALVE 3/8"	
7	2	2	600.270	NIPPLE 3/8" GAS - 3/8"GAS	
8	2	2	630.315	FITTING BANJO 3/8"	
9	2	2	600.040	SCREW 3/8"	
10	2	2	250.238	CYLINDER ø50-30	
11				DELETED	
12				DELETED	
13	6	6	610.035	HOSE COLLAR ø18	
14	6	6	610.037	SCREW M6x25 DIN 912	

TABLE PART NO 920.371

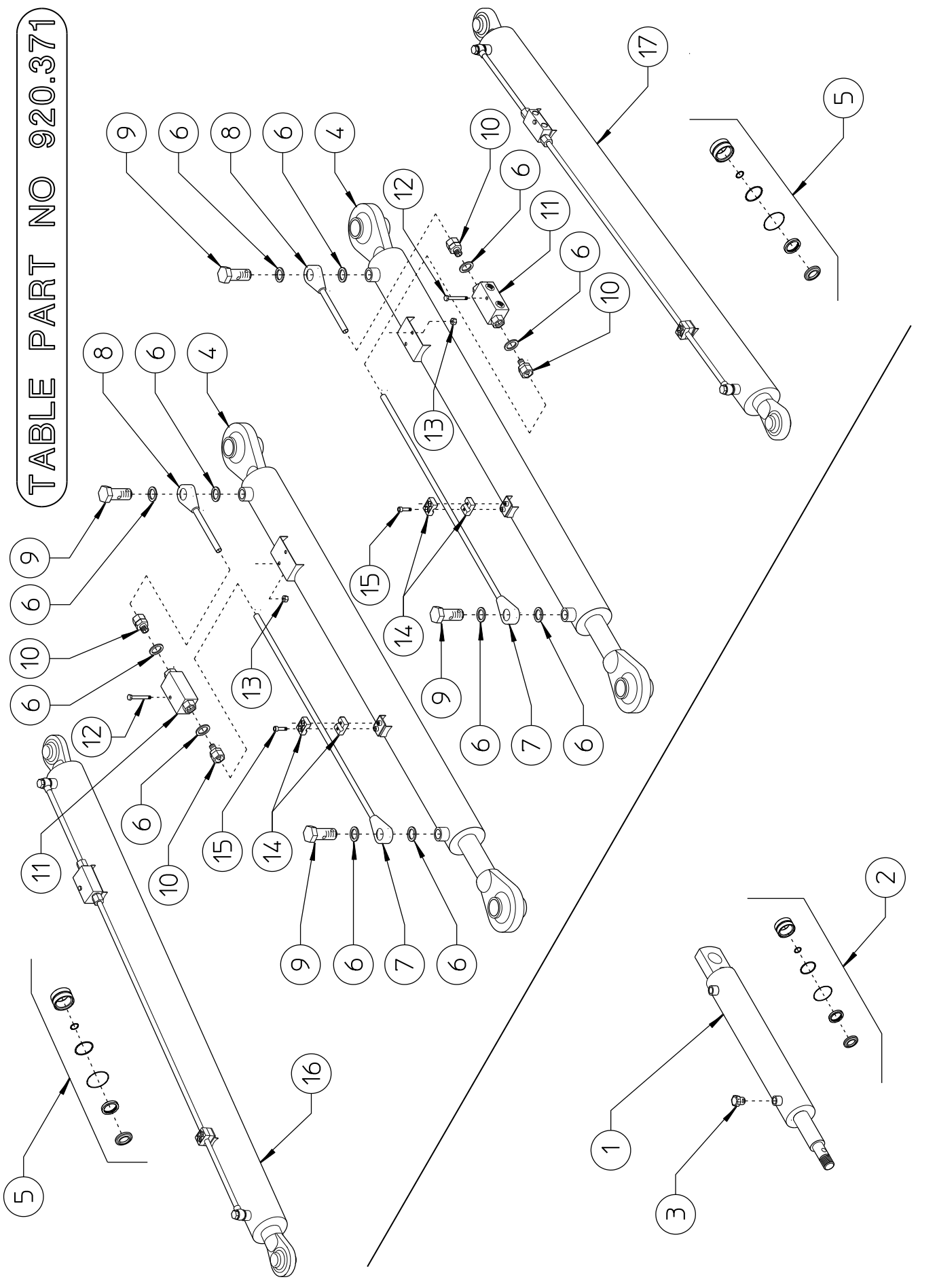

TABLE PART NO 920.371 - CYLINDER WITH VALVE AND ACCESORIES (10-12 WHEELS)					
ITEM	Q.ty	Q.ty	SITREX	DESCRIPTION	NOTE
	MKE/10	MKE/16	PART NO		
1	2	2	250.238	CYLINDER ø50-30	
2	2	2	640.027	SET OF GASKET ø50-30	
3	2	2	620.012	PLUG 3/8"	
4	2	2	250.263	CYLINDER ø70-45	
5	2	2	640.028	SET OF GASKET ø70-45	
6	12	12	620.452	WASHER ø3/8" BONDED	
7	2	2	210.195	TUBE ø12 L.950-37,4"	
8	2	2	210.194	TUBE ø12 L.200-7,87"	
9	4	4	600.040	SCREW ø3/8"	
10	4	4	610.469	FITTING 3/8"-ø12	
11	2	2	600.799	LOCK VALVE 3/8"	
12	2	2	600.869	SCREW M6x40 DIN 931	
13	2	2	600.472	NUT M6 DIN 980	
14	4	4	610.423	HOSE COLLAR ø12	
15	4	4	610.424	SCREW M6x20 DIN 912	
16	1	1	250.298	RH CYLINDER ø70-45 WITH VALVE	
17	1	1	250.299	LH CYLINDER ø70-45 WITH VALVE	



sitrex AGRICULTURAL MACHINERY[®] Spa

Zona Industriale-Viale Grecia, 8
06018 TRESTINA-(Perugia)-ITALY
Tel. +39.075.8540021-Telefax +39.075.8540523
e-mail: sitrex@sitrex.it www.sitrex.com

